

Using resistive touch screens for human/machine interface

By Rick Downs (Email: downs_rick@ti.com)

Applications Engineering Manager, Data Acquisition Products

Introduction

Touch-screen interfaces are effective in many information appliances, in personal digital assistants (PDAs), and as generic pointing devices for instrumentation and control applications. Getting the information from a touch screen into a microprocessor can be challenging. This article introduces the basics of how resistive touch screens work and how to best convert these analog inputs into usable digital data. Issues such as settling time, noise filtering, and speed trade-offs are addressed.

Resistive touch screens

Resistive touch screens consist of a glass or acrylic panel that is coated with electrically conductive and resistive layers made with indium tin oxide (ITO) (see Figure 1). The thin layers are separated by invisible spacers.

Resistive screens are generally the most affordable type of touch screen, which explains their success in high-use applications like PDAs and Internet appliances. Although clarity is not as good as with other touch-screen types, resistive screens are very durable. The only concern is that the resistive layers can be damaged by a very sharp object.

The two most popular resistive architectures use 4-wire or 5-wire configurations, as shown in Figure 2 (the 5-wire configuration uses the second layer as a wiper contact, not shown here). The circuits determine location in two coordinate-pair dimensions, although a third dimension can be added for measuring pressure in 4-wire configurations.

Figure 1. Resistive touch screen

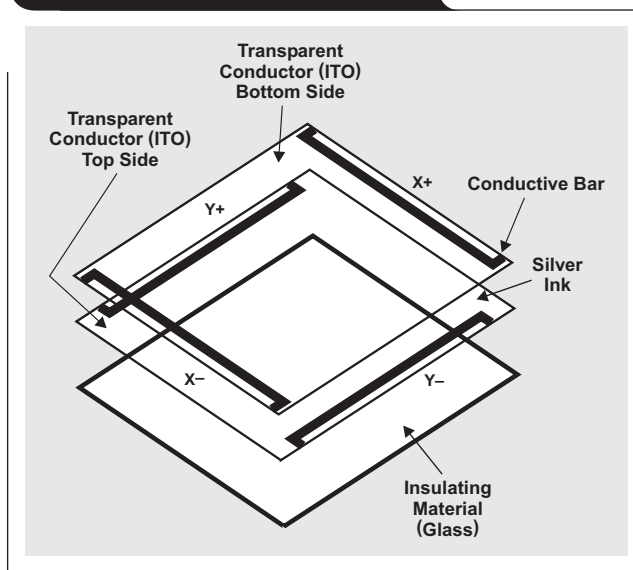

Texas Instruments (TI) offers specialized analog-to-digital converters (ADCs) for interfacing to these two popular resistive touch screens. Since the majority of applications use 4-wire touch screens, the rest of this article concentrates on this architecture, although the same advice applies to the 5-wire screens and the ADS7845, TI's 5-wire touch-screen controller.

Figure 2. Touch-screen circuit configurations

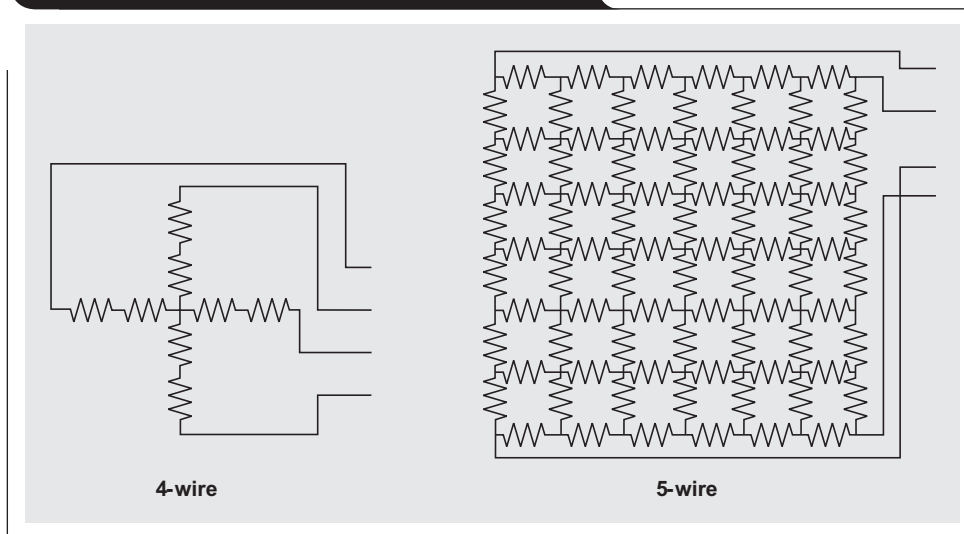

Resistive touch-screen controllers

When a position is measured on a 4-wire touch screen, voltage is applied across the screen in the Y direction; and a touch presses the layers together, where a voltage can be read from one of the X electrodes. The contact made as a result of the touch creates a voltage divider at that point, so the Y coordinate can be determined; the process then repeats with the X direction being driven, and a reading is taken from one of the Y electrodes.

A touch-screen controller is simply an ADC that has built-in switches to control which electrodes are driven and which electrodes are used as the input to the ADC. The ADC can often be operated with different reference modes: single-ended or differential.

Single-ended configuration

In a single-ended configuration, the ADC reference is supplied between a reference input (V_{REF}) and ground. Very often, V_{REF} is actually the power supply voltage.

The ADC output is then a ratio of the input signal to the V_{REF} voltage. Since the touch screen is a voltage divider, this may seem sensible. However, there are several possible errors that may show up due to the driver switches, such as gain and offset errors from temperature, voltage drops in the switches, etc.

If the reference voltage is not the power supply, then power-supply variations could cause errors, since the power supply is the voltage placed across the screen; and, while it varies, the reference voltage will not.

Variations in touch-screen impedance can also cause gain or offset errors.

Differential configuration

In the differential configuration, the ADC's voltage reference is taken directly across the touch screen, eliminating driver variations, power-supply changes, and even changes in the touch-screen impedance. The output of the ADC is still the ratio of the input to V_{REF} . V_{REF} is now the voltage across the screen, and the output is a true reflection of the position of the touch on the screen.

Using a differential or ratiometric measurement technique like this provides much more accurate results, particularly in systems with noisy power supplies or where the touch screen is located a significant distance away from the controller.

Touch-screen settling time

When the touch panel is pressed or touched, there are two mechanisms that will affect the voltage level at the contact point. These two mechanisms will cause the voltage across the touch panel to "ring" and then to settle (decay) down slowly to a stable dc value.

The two mechanisms are:

1. Mechanical bouncing caused by vibration of the top layer sheet of the touch panel when the panel is pressed.
2. The charging of the parasitic capacitance between the top and bottom layer sheets of the touch panel and at the input of the ADC that occurs when the drivers turn on, and inductive effects from the leads connecting the panel to the drivers in the controller.

Difference between single-ended and differential modes

In both single-ended and differential modes, the ADC acquires (samples) the input analog voltage from the touch panel for some time, t_{ACQ} (see Figure 3). The input voltage has to settle within t_{ACQ} in order for the ADC to capture the correct voltage.

Turning the drivers on causes the touch panel's voltage to rise rapidly and then settle to the final value, as shown in Figure 3. To acquire the correct value for conversion, the acquisition must be complete when the touch panel has completely settled. There are two ways of accomplishing this.

One method (shown in Figure 3) uses the ADC in single-ended mode and a relatively slow clock. A slow clock extends the acquisition time, since it extends the clock periods used for acquisition. The drivers turn on at the beginning of the first of three clock periods (for simple controllers like the ADS7843, ADS7846, TSC2003, and TSC2046). The panel must then settle completely during

Figure 3. Timing diagram of single-ended-mode operation for TSC2046

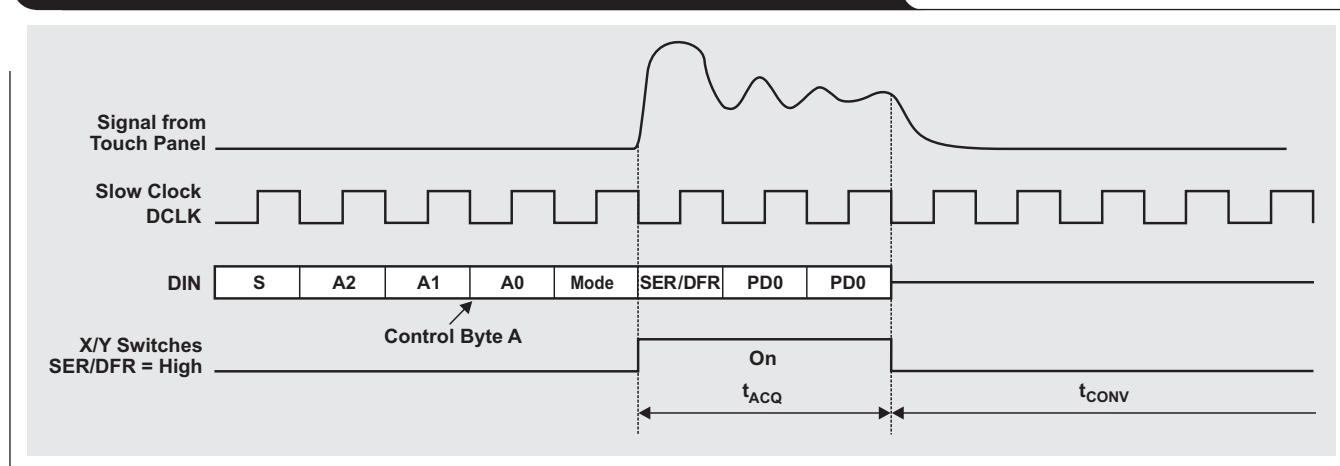

the following two clock cycles, so that at the end of the third clock cycle, the acquired voltage is accurate.

The second method (shown in Figure 4) uses the differential mode and a much faster clock rate. Control byte B turns the drivers on and, as before, the touch panel's voltage rises rapidly and begins to settle. In this case, a conversion is done, and then a second conversion is begun, by sending control byte C. If control bytes B and C are the same, the internal X/Y switch of the ADC will not turn off after completing a conversion for control byte B. Thus, the touch panel voltage will be settled by the time the conversion from control byte C begins, and this conversion will be accurate. This method requires that the conversion result from control byte B be discarded, as it will not be

accurate since its acquisition period occurred when the touch panel voltage was still ringing.

An advantage to using the second method is the potential for power savings. After the end of conversion for control byte C, the controller can go into power-down mode and wait for the next sampling period. In the slow-clock case, the next sample period may have to come immediately after the current conversion, leaving no time for power down.

Using a fast clock in single-ended mode (Figure 5) would not be of any help, because the drivers turn off between conversions. This results in the touch panel's voltage rising at the beginning of each conversion, which never gives the touch panel a chance to settle.

Figure 4. Using a fast clock in differential mode for TSC2046

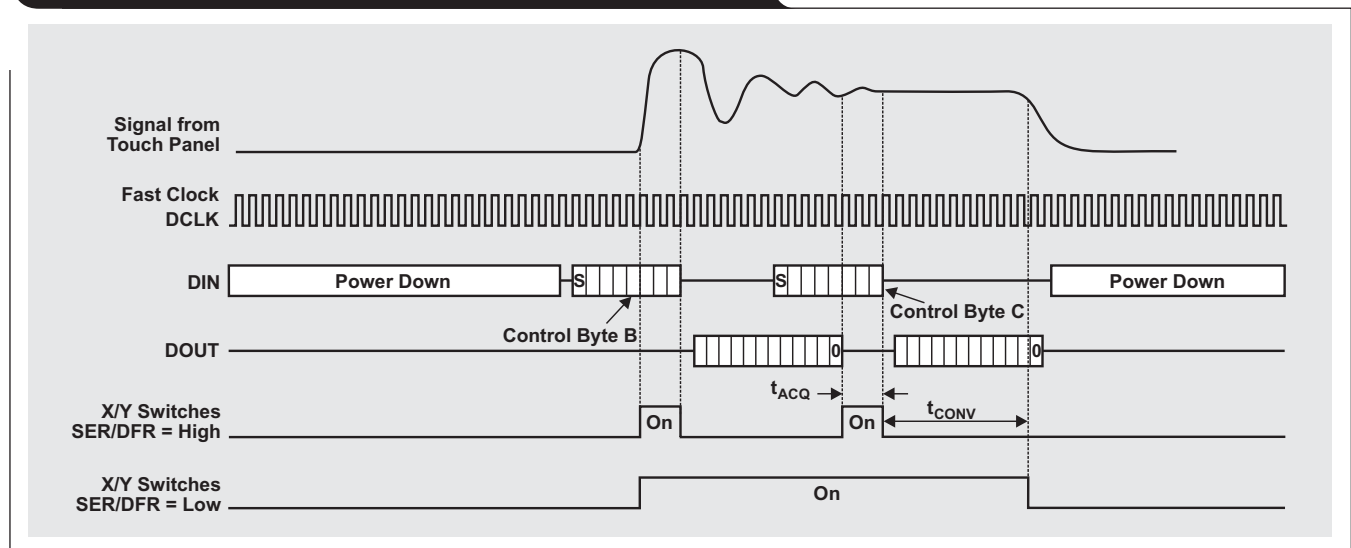
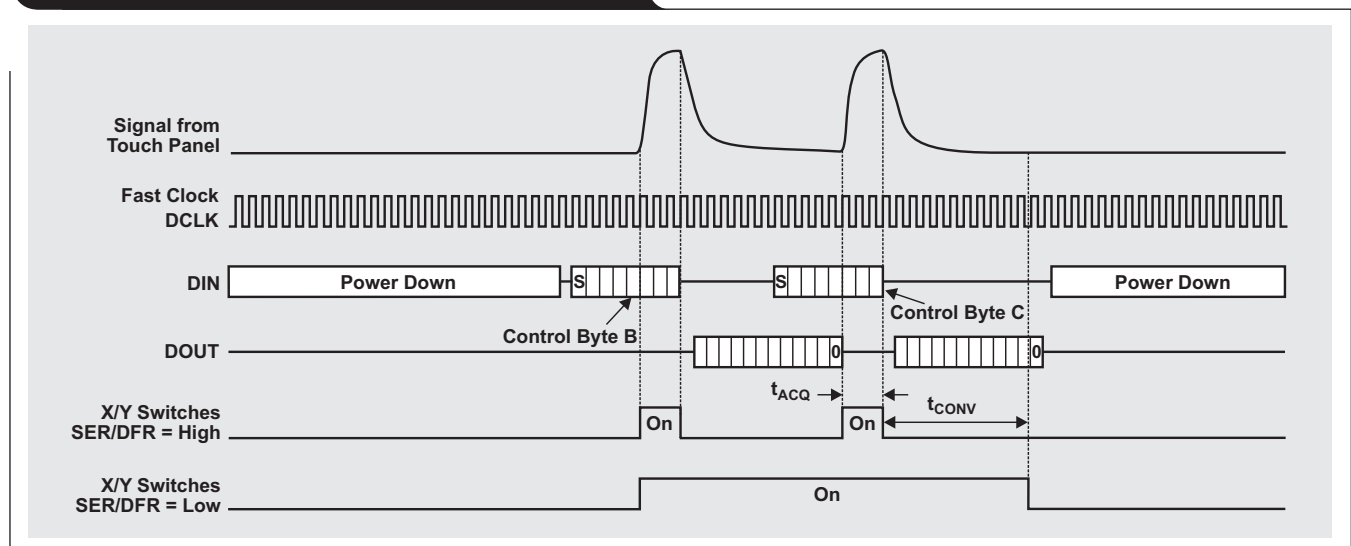

Figure 5. Using a fast clock in single-ended mode



Making the ADC results usable for a human interface

Since several measurements for one coordinate pair are being taken, the designer has the opportunity to do some processing on this data, like averaging. This will help prevent spurious readings that may make dealing with the human interface difficult.

Touch-screen acquisition flowchart

Figure 6 shows a typical flowchart for a touch screen. In its idle state, the touch-screen controller's pen interrupt (PENIRQ) line is held high. When a touch occurs on the screen, the PENIRQ line is driven low, signaling the host processor that it needs to start taking coordinate readings.

The host will then turn on the X drivers, wait for settling to occur, and then take several readings of the X coordinate. The host will then turn off the X drivers and turn on the Y drivers. After waiting again for the screen to settle, the host will take several readings of the Y coordinate. The

same process can be used for taking Z-coordinate readings if touch pressure is also to be measured.

The Z-axis measurement for touch pressure is used in applications such as signature capture, where the pressure information is important for recognizing the authenticity of a signature. However, even in conventional X-Y applications, using the Z-axis measurement can be helpful in determining whether a touch data point is valid. Using this measurement can help prevent spurious readings that may occur due to the mechanical bouncing of the touch screen plates, simply because readings where the pressure is too light are not accepted. A complete description of the Z-axis measurement process can be found in the datasheets for touch-screen controllers with this capability.

Data-averaging algorithm

The averaging algorithm reduces noise resulting from contact bounce during use of the touch screen. Successive X and Y samples are tested to determine if their values

Figure 6. Touch-screen acquisition flowchart

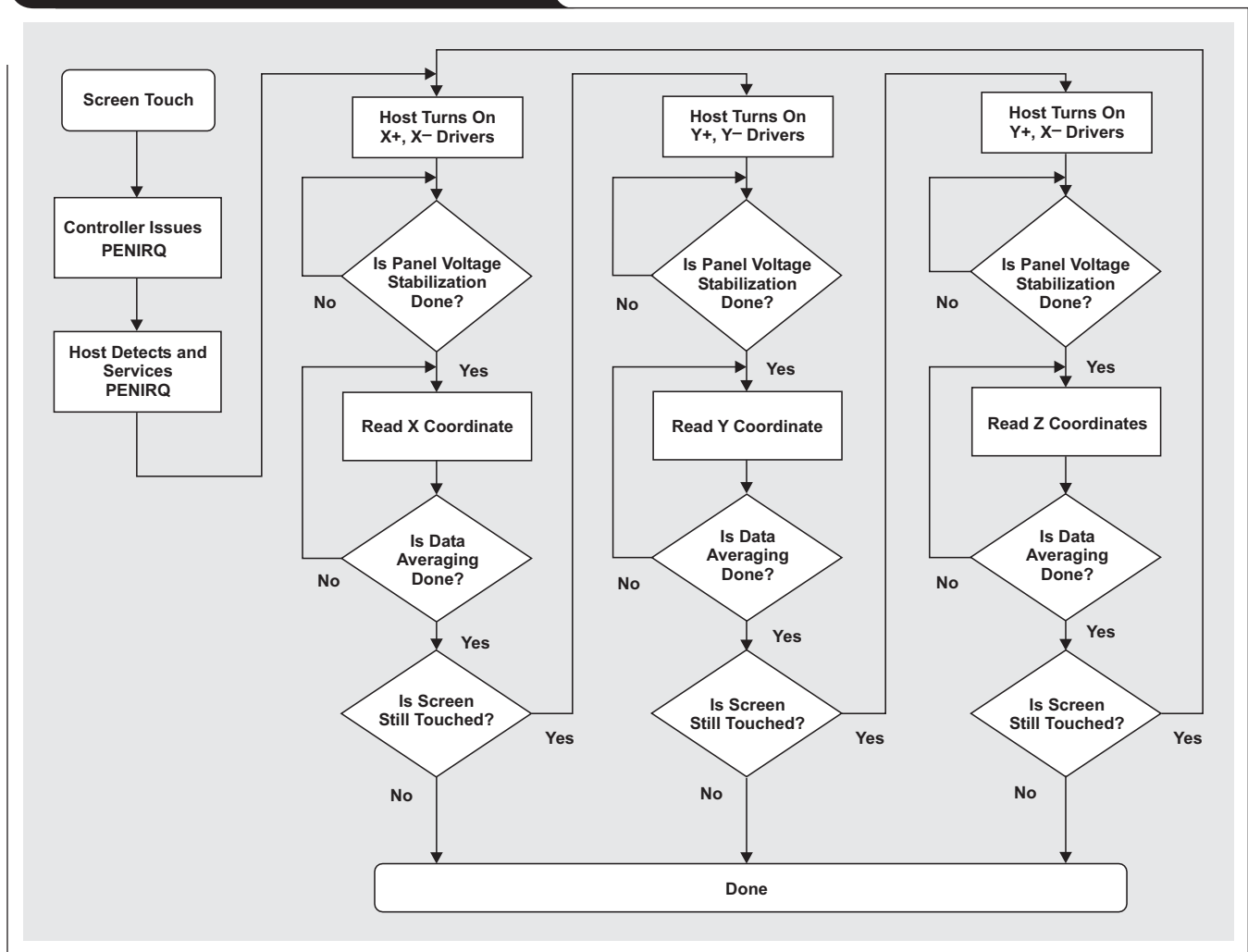

differ by no more than a certain range. If one or more samples falls outside this range, the samples are discarded and the process is restarted. This is continued until successive X samples (then Y samples) fall within the range. The average of these values is used as the X and Y coordinates, respectively.

Once independent X and Y samples are obtained, coordinate pairs are sampled to eliminate the effects of noise. If a sample does not fall within an internal range, all X and Y coordinate pairs are discarded and the independent X and Y sequence is restarted. Once acceptable coordinate pairs have been obtained, an average coordinate pair is determined.

The entire process just described can be done by the processor or by some of the newer, intelligent controllers like TI's TSC2200, TSC2301, or TSC2101. These devices take care of the settling-time issues and other touch-screen interface problems previously described; they also relieve the host CPU from the tasks of reading and writing over the serial interface so often. These intelligent devices can be programmed to respond to a touch, take a complete set of coordinate readings, average several readings, and then—only when this entire process is complete—interrupt the host processor. The host then does only one

reading of all coordinates and need not do any further averaging or noise reduction.

These highly integrated devices come paired with keypad controllers (TSC2200) or audio codecs (TSC2301, TSC2101) to provide complete human/machine interface controllers in a single package.

Reference

For more information related to this article, you can download an Acrobat Reader file at www-s.ti.com/sc/techlit/litnumber and replace "litnumber" with the **TI Lit. #** for the materials listed below.

Document Title	TI Lit. #
1. Skip Osgood, CK Ong, and Rick Downs, "Touch Screen Controller Tips," Application Reportsbaa036

Related Web sites

dataconverter.ti.com

www.ti.com/sc/device/partnumber

Replace *partnumber* with ADS7843, ADS7845, ADS7846, TSC2003, TSC2046, TSC2101, TSC2200, or TSC2301

IMPORTANT NOTICE

Texas Instruments Incorporated and its subsidiaries (TI) reserve the right to make corrections, modifications, enhancements, improvements, and other changes to its products and services at any time and to discontinue any product or service without notice. Customers should obtain the latest relevant information before placing orders and should verify that such information is current and complete. All products are sold subject to TI's terms and conditions of sale supplied at the time of order acknowledgment.

TI warrants performance of its hardware products to the specifications applicable at the time of sale in accordance with TI's standard warranty. Testing and other quality control techniques are used to the extent TI deems necessary to support this warranty. Except where mandated by government requirements, testing of all parameters of each product is not necessarily performed.

TI assumes no liability for applications assistance or customer product design. Customers are responsible for their products and applications using TI components. To minimize the risks associated with customer products and applications, customers should provide adequate design and operating safeguards.

TI does not warrant or represent that any license, either express or implied, is granted under any TI patent right, copyright, mask work right, or other TI intellectual property right relating to any combination, machine, or process in which TI products or services are used. Information published by TI regarding third-party products or services does not constitute a license from TI to use such products or services or a warranty or endorsement thereof. Use of such information may require a license from a third party under the patents or other intellectual property of the third party, or a license from TI under the patents or other intellectual property of TI.

Reproduction of information in TI data books or data sheets is permissible only if reproduction is without alteration and is accompanied by all associated warranties, conditions, limitations, and notices. Reproduction of this information with alteration is an unfair and deceptive business practice. TI is not responsible or liable for such altered documentation.

Resale of TI products or services with statements different from or beyond the parameters stated by TI for that product or service voids all express and any implied warranties for the associated TI product or service and is an unfair and deceptive business practice. TI is not responsible or liable for any such statements.

Following are URLs where you can obtain information on other Texas Instruments products and application solutions:

Products

Amplifiers	amplifier.ti.com
Data Converters	dataconverter.ti.com
DSP	dsp.ti.com
Interface	interface.ti.com
Logic	logic.ti.com
Power Mgmt	power.ti.com
Microcontrollers	microcontroller.ti.com

Applications

Audio	www.ti.com/audio
Automotive	www.ti.com/automotive
Broadband	www.ti.com/broadband
Digital control	www.ti.com/digitalcontrol
Military	www.ti.com/military
Optical Networking	www.ti.com/opticalnetwork
Security	www.ti.com/security
Telephony	www.ti.com/telephony
Video & Imaging	www.ti.com/video
Wireless	www.ti.com/wireless

TI Worldwide Technical Support

Internet

TI Semiconductor Product Information Center Home Page
support.ti.com

TI Semiconductor KnowledgeBase Home Page
support.ti.com/sc/knowledgebase

Product Information Centers

Americas

Phone	+1(972) 644-5580	Fax	+1(972) 927-6377
Internet/Email	support.ti.com/sc/pic/americas.htm		

Europe, Middle East, and Africa

Phone			
Belgium (English)	+32 (0) 27 45 54 32	Netherlands (English)	+31 (0) 546 87 95 45
Finland (English)	+358 (0) 9 25173948	Russia	+7 (0) 95 7850415
France	+33 (0) 1 30 70 11 64	Spain	+34 902 35 40 28
Germany	+49 (0) 8161 80 33 11	Sweden (English)	+46 (0) 8587 555 22
Israel (English)	1800 949 0107	United Kingdom	+44 (0) 1604 66 33 99
Italy	800 79 11 37		
Fax	+(49) (0) 8161 80 2045		
Internet	support.ti.com/sc/pic/euro.htm		

Japan

Fax			
International	+81-3-3344-5317	Domestic	0120-81-0036
Internet/Email			
International	support.ti.com/sc/pic/japan.htm		
Domestic	www.tij.co.jp/pic		

Asia

Phone			
International	+886-2-23786800		
Domestic	Toll-Free Number		
Australia	1-800-999-084	New Zealand	0800-446-934
China	800-820-8682	Philippines	1-800-765-7404
Hong Kong	800-96-5941	Singapore	800-886-1028
Indonesia	001-803-8861-1006	Taiwan	0800-006800
Korea	080-551-2804	Thailand	001-800-886-0010
Malaysia	1-800-80-3973		
Fax	886-2-2378-6808	Email	tiasia@ti.com
Internet	support.ti.com/sc/pic/asia.htm		ti-china@ti.com

C011905

Safe Harbor Statement: This publication may contain forward-looking statements that involve a number of risks and uncertainties. These "forward-looking statements" are intended to qualify for the safe harbor from liability established by the Private Securities Litigation Reform Act of 1995. These forward-looking statements generally can be identified by phrases such as "TI or its management believes," "expects," "anticipates," "foresees," "forecasts," "estimates" or other words or phrases of similar import. Similarly, such statements herein that describe the company's products, business strategy, outlook, objectives, plans, intentions or goals also are forward-looking statements. All such forward-looking statements are subject to certain risks and uncertainties that could cause actual results to differ materially from those in forward-looking statements. Please refer to TI's most recent Form 10-K for more information on the risks and uncertainties that could materially affect future results of operations. We disclaim any intention or obligation to update any forward-looking statements as a result of developments occurring after the date of this publication.

Trademarks: All trademarks are the property of their respective owners.

Mailing Address: Texas Instruments
Post Office Box 655303
Dallas, Texas 75265

© 2005 Texas Instruments Incorporated

SLYT209A